



InHand Networks



CT Power Harvesting, Reliable Main & Backup Power,
High-precision Sync, Remote Maintenance

InHand Wireless Overhead-lines System Concentrator (Line-mounted)

Smart power distribution is an important sector of smart grid. One great challenge faces the operation team of distribution networks is how to quickly and accurately locate the faulty section when power line faults, especially low-current ground faults occur. Existing distribution automation, feeder automation, and fault indicating technologies have the problems of high investment, requiring power off for deployment, low accuracy, etc. InHand Wireless Overhead-lines System, the smart distribution lines monitoring system launched by InHand Networks, can accurately identify the type of power line faults and quickly locate the faulty section based on innovative technologies of high-precision measurement and high-speed wave-recording of line currents, thus significantly shorten response and processing time of power line faults, improve power supply reliability.

The concentrator is the communication bridge between overhead line sensors and main station. By a hybrid of short and long range wireless networking, the system has the functions of channel monitoring, switching, and fault alarming, supports system diagnosing, self-recovery, and transmission breakpoint resuming. The high-reliability power supply consisting CT on-line power harvesting as main and maintenance-free accumulator as backup power can ensure continuous stable operation, allowing utilities to monitor status of power lines and line faults in real-time. With big-data based comprehensive analysis of the status of distribution lines, the system can generate power line status analysis, including line faults, load current, energy quality, etc., and provide solid data support for the structural optimization of distribution network.

Application Case

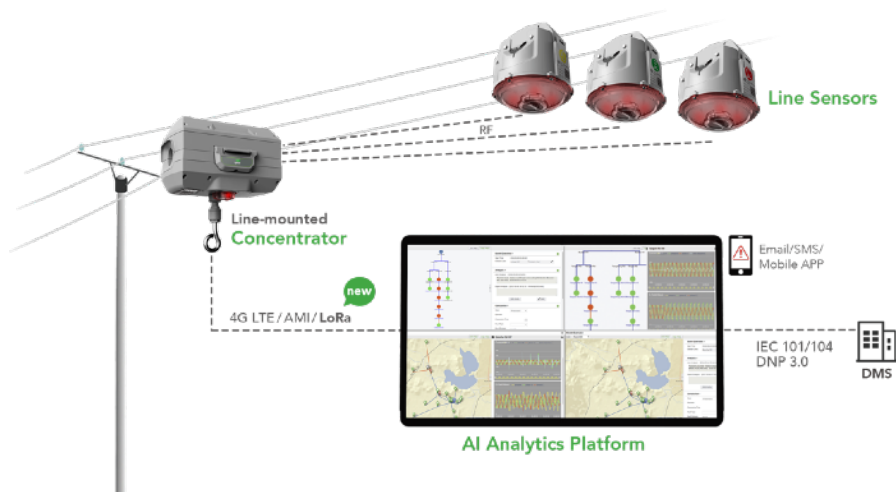

Features and Advantages

- + High-reliability power supply system, with CT on-line harvesting as main and super capacitor and rechargeable battery as backup power
 - + Real-time two-way communication between concentrator and main station, by hybrid of short and long range wireless networking
 - + High precision (20 μ s) wireless three-phase time synchronization
 - + Accurate on-site detection and locating of ground faults, with transient zero sequence current and electric field signal acquired by three phase synthesis
 - + Precision (1 μ s) GPS Timing based absolute timescale
 - + 4G and BLE, support remote maintenance and upgrade
 - + Live installation and removal, IP67
- **Flexible Networking, Safe Transmission**
The concentrators build short range wireless network in-between, supporting star topology; and establish communication with the main station monitoring platform through 4G based cellular network, to upload data to main station and realize the monitoring of faults and operation status of the distribution network.
 - **Precision GPS Timing Based Accurate Absolute Timescale**
The concentrator is embedded with a GPS timing module, precision of time service reaching 1 μ s. By time service through short-range wireless connection, the overhead line sensors can acquire an absolute timescale with 20 μ s precision for remote-signaling, telemetry and wave-recording data.
 - **Accurate On-site Detection and Locating of Ground Faults with Three-phase Synthesized Zero Sequence Current and Electric Field Signal**
The system can realize accurate on-site detection and locating of ground faults by acquiring transient zero sequence current and electric field signal through three phase synthesis. It can also upload the waveform of the faulty moment recorded by overhead line sensors to the main station for fault analysis, retracing and sourcing.
 - **Reliable and Stable Communications**
Reliable industrial-grade design, industrial-grade cellular communication module from major brand. Support channel monitoring, channel switching and fault alarming; system diagnosing and self-recovery; and transmission breakpoint resuming when communication recovers from interruption, avoiding loss of data.
 - **Ultra-low Power Consumption**
Motherboard of the concentrator adopts low power consumption CPU and industrial-grade cellular communication module. By special programming technology, the concentrator achieves real-time two-way communication with the monitoring platform software and overhead line sensors on ultra-low power consumption.
 - **High-reliability Power Supply System**
The concentrator uses CT power harvesting as main, and super capacitor and rechargeable battery as backup power when the line is out of power or line current does not meet the requirements of power harvesting. The backup power can supply for continuous operation of the concentrator for 24 hours. The embedded high-performance processor will switch between main and backup power according to real-time detection of the CT harvesting, super capacitor and rechargeable battery.
 - **Remote Maintenance and Upgrade**
Support remote maintenance and upgrade, either batch or automatically one-by-one, making maintenance safe and convenient. Also support text message management.
 - **Live Installation and Removal, Safe and Convenient**
Use insulated hot stick to live install or remove the device which is safe and convenient. The line-mounted concentrator is bolt-fixed so that installing and removing of the device will not damage the line. While it fastens to the line more reliably, not easy to slide or fall off, enabled good installation consistency; and the power harvesting electromagnetic chip locks tightly, will not vibrate or whistle during harvesting, enabled stable power harvesting effect.
 - **High Protection Rating, Rugged for Challenging Environments**
Ruggedized to ensure long hours of stable operation even under harsh conditions, e.g. storms and typhoons of force 8, featuring high EMC level, extremely wide tolerance of input voltages and operating temperatures, IP67 protection rating, and treated structural parts that are corrosion and rust proof and salt spray corrosion proof.

Product Specifications

IWO-HX Wireless Communication Specifications			
Short-range Wireless Communication			
Communication Distance	≥ 100m	Transmission Rate	250kbps
Transmit Power	≤ 10mW (10dBm)	Network Topology	Star
RX Sensitivity	≥ -90dBm	Directionality	All directions
Wireless Communication			
Network Access	Wireless DDN (APN) /VPDN		
Network Authentication	Support CHAP, PAP authentication		
UIM/SIM Card	1.8V/3V, drawer-type card slot		
GPS Timing Module			
First-time Startup Time	35 seconds	Startup Time (non first-time)	1 second
Time Service Precision	1μs		
Regulations and Protocols			
Electric Power Regulation	Support DL/T 634.5 101-2002, DL/T 634.5 104-2002, and DNP3		
Network Security			
Device Management Security	Support login by user types: administrator, maintainer		
Service Life			
Service Life	> 8 years		
MTBF	27.3 years (whole system, incl. sensors and concentrator)		

IWO-HX Hardware Specifications			
Power Supply and Consumption			
Main Power Supply	CT on-line power harvesting		
Battery	Super capacitor and rechargeable lithium battery		
Average Hibernating Consumption (offline, system hibernating)	≤ 100uA@3.6V	Average Standby Consumption (offline, no communication)	≤ 100uA@3.6V
Average Operating Consumption (Online, regular communication)	≤ 55mA@3.6V	Max. Operating Consumption (Online, continuous communication)	≤ 300mA@3.6V
Mechanical Specifications			
Dimensions (WxHxD)	248mm (269mm incl. screw part) x 163mm x162mm		
Weight	≤ 3kg	Protection Rating	IP67
Operating Environment			
Operating Temperature	-40 ~ +70 °C	Storage Temperature	-40 ~ +85 °C
Ambient Humidity	5% ~ 95% (non-condensing)		
EMC			
ESD Immunity	Level 4	RF Field Radiation Immunity	Level 4
Surge Immunity	Level 4	Fast Transient Pulse Train Immunity	Level 4
Power Frequency Magnetic Field Immunity	Level 5	Damped Oscillatory Electric Field Immunity	Level 5
Pulse Magnetic Field Immunity	Level 5		

Dimensions (mm)

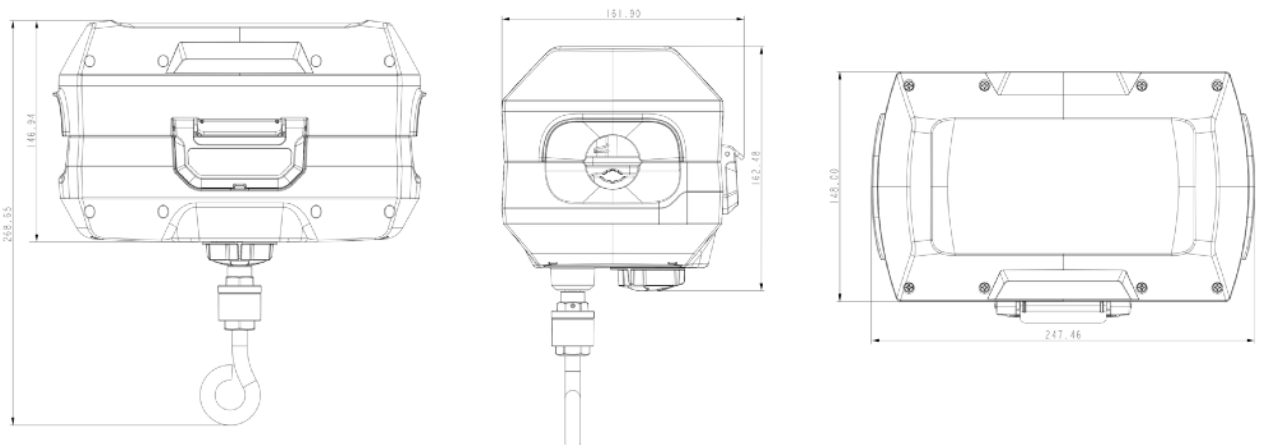

Ordering Guide

Concentrator Model	Model code: IWO-HD/HX-<WMNN>-<C/U/M/S>-<5/6>-<A/B/C/D/E/F>-<2/3/N>				
	<WMNN>: Cellular Type & Module	<C/U/M/S>: Short-range Frequency	<5/6>: Line Frequency	<A/B/C/D/E/F>: Battery	<2/3/N>: Solar Power
IWO-HD/HX-<TL00>-<C/U/M/S>-<5/6>-<A/B/C/D/E/F>-<2/3/N>	China - LTE CAT4: LTE-FDD Band1/3/5/8 LTE-TDD Band38/39/40/41 TD-SCDMA Band34/39 UMTS(DC-HSPA+) Band 1/5 EDGE/GPRS/GSM 850/900/1800/1900MHz				
IWO-HD/HX-<FH20>-<C/U/M/S>-<5/6>-<A/B/C/D/E/F>-<2/3/N>	Europe, Asia Pacific - LTE CAT4: LTE-FDD Band 1/2/3/4/5/7/8/20 UMTS(DC-HSPA+) Band1/2/5/8 EDGE/GPRS/GSM 850/900/1800/1900MHz	C: 470-510MHz China, Thailand		A: 7.2Ah Lead-acid B: 12Ah Lead-acid	
IWO-HD/HX-<FB53>-<C/U/M/S>-<5/6>-<A/B/C/D/E/F>-<2/3/N>	Europe - LTE CAT1: LTE-FDD Band 3/7/20 EDGE/GPRS/GSM 900/1800/MHz	U: 915-928MHz North America, New Zealand	5: 50Hz 6: 60Hz	C: 40Ah Li-phosphate D: 40Ah Gel	2: 20W 3: 30W
IWO-HD/HX-<FB78>-<C/U/M/S>-<5/6>-<A/B/C/D/E/F>-<2/3/N>	Australia, South America - LTE CAT4: LTE-FDD CAT4 Band 1/3/5/7/8/28 UMTS(DC-HSPA+) 850/900/1900/2100	M: 866MHz Middle East S: 919-923MHz Malaysia		E: 12Ah Li-phosphate F: 3.3Ah Li-phosphate	N: No solar power
IWO-HD/HX-<FB13>-<C/U/M/S>-<5/6>-<A/B/C/D/E/F>-<2/3/N>	North America, AT&T, T-Mobile - LTE CAT1: LTE-FDD Band2/4/12				
IWO-HD/HX-<FB02>-<C/U/M/S>-<5/6>-<A/B/C/D/E/F>-<2/3/N>	Global, North America AT&T, Verizon Wireless: LTE CAT-M & NB1				
Example	IWO-HD-FH20-C5B2: Concentrator, pole-mounted, supports Europe and Asia Pacific networks, short-range communication frequency is 470-510MHz, applicable to 50Hz 10KV power lines, packaged with 12Ah lead-acid battery, 20W solar panel.				

About Us

InHand Networks is a global leader of Industrial IoT, with a record of tremendous success following groundbreaking innovation since our inception in 2001.

InHand serves world-class partners and customers with industrial M2M routers, gateways, industrial Ethernet switches, rugged computers and IoT management platforms. We provide IoT solutions for various vertical markets including Smart Grid, Industrial Automation, Remote Machine Monitoring, Smart Vending, Smart City, Retail and more.

Proudly bearing the marks of AWS Select Technology Partner, Schneider Electric TPP Certified Technology Partner, and Rockwell Automation Encompass Product Partner in Asia-Pacific, InHand Networks defines industrial innovation and reliability.



3900 Jermantown Rd., Suite 150, Fairfax, VA 22030 USA
T: +1 (703) 348-2988
E: info@inhandnetworks.com
www.inhandnetworks.com